



**INSTITUTO DE CIENCIAS
DE LA CONSTRUCCIÓN
EDUARDO TORROJA**

C/ Serrano Galvache n. 4 28033 Madrid (Spain)
Tel.: (34) 91 302 04 40 Fax: (34) 91 302 07 00
direccion.ietcc@csic.es www.ietcc.csic.es

European Technical Assessment

**ETA 12/0397
of 27/07/2017**

English translation prepared by IETcc. Original version in Spanish language

General Part

Technical Assessment Body issuing the ETA designated according to Art. 29 of Regulation (EU) 305/2011:

Instituto de Ciencias de la Construcción Eduardo Torroja (IETcc)

Trade name of the construction product

**Anchor MTP
Anchor MTP-G
Anchor MTP-X**

Product family to which the construction product belongs

Torque controlled expansion anchor made of galvanized steel or sherardized steel of sizes M8, M10, M12, M16, M20 and M24 for use in concrete.

Manufacturer

Index - Técnicas Expansivas S.L.
Segador 13
26006 Logroño (La Rioja) Spain.
website: www.indexfix.com

Manufacturing plants

Index plant 2

This European Technical Assessment contains

14 pages including 3 annexes which form an integral part of this assessment.

This European Technical Assessment is issued in accordance with regulation (EU) No 305/2011, on the basis of

European Technical Assessment EAD 330232-00-0601 "Mechanical Fasteners for use in concrete", ed. October 2016

This version replaces

ETA 12/0397 issued on 17/12/2015

English translation prepared by IETcc

This European Technical Assessment is issued by the Technical Assessment Body in its official language. Translations of this European Technical Assessment in other languages shall fully correspond to the original issued document and should be identified as such.

This European Technical Assessment may be withdrawn by the issuing Technical Assessment Body, in particular pursuant to information by the Commission according to article 25 (3) of Regulation (EU) No 305/2011.

SPECIFIC PART

1. Technical description of the product

The Index MTP wedge anchor in the range of M8, M10, M12, M16, M20 and M24 is an anchor made of galvanised steel. The Index MTP-G wedge anchor in the range of M8, M10, M12, M16 and M20 is an anchor made of sherardized steel. The Index MTP-X wedge anchor in the range of M8, M10, M12, M16 and M20 is an anchor made of galvanized steel. The anchor is installed into a predrilled cylindrical hole and anchored by torque-controlled expansion. The anchorage is characterised by friction between expansion clip and concrete.

Product and product description is given in annex A.

2. Specification of the intended use in accordance with the applicable European Assessment Document.

The performances given in section 3 are only valid if the anchor is used in compliance with the specifications and conditions given in annex B.

The verifications and assessment methods on which this European Technical Assessment is based lead to the assumption of a working life of the anchor of at least 50 years. The indications given on the working life cannot be interpreted as a guarantee given by the producer, but are to be regarded only as a mean to choosing the right products in relation to the expected economically reasonable working life of the works.

3. Performance of the product and references to the methods used for its assessment

3.1 Mechanical resistance and stability (BWR 1)

Essential characteristic	Performance
Characteristic resistance under static or quasi static loading	See annexes C1 to C3
Displacements under tension and shear loads	See annex C4
Characteristic resistance under seismic loading categories C1 and C2	See annex C5 and C6

3.2 Safety in case of fire (BWR 2)

Essential characteristic	Performance
Reaction to fire	Anchorage satisfy requirements for class A1
Resistance to fire	See annex C7

3.3 Hygiene, health and the environment (BWR 3)

This requirement is not relevant for the anchors.

English translation prepared by IETcc

3.4 Safety in use (BWR 4)

The essential characteristics regarding safety in use are included under the basic works requirements Mechanical resistance and stability.

3.5 Protection against noise (BWR 5)

This requirement is not relevant for the anchors.

3.6 Energy economy and heat retention (BWR 6)

This requirement is not relevant for the anchors.

3.7 Sustainable use of natural resources (BWR 7)

No performance determined

4. Assessment and Verification of Constancy of Performances (hereinafter AVCP) system applied, with reference to its legal base

The applicable European legal act for the system of Assessment and Verification of Constancy of Performances (see annex V to Regulation (EU) No 305/2011) is 96/582/EC.

The system to be applied is 1.

5. Technical details necessary for the implementation of the AVCP system, as provided for in the applicable European Assessment Document.

The technical details necessary for the implementation of the AVCP system are laid down in the quality plan deposited at Instituto de ciencias de la construcción Eduardo Torroja.



Instituto de ciencias de la construcción Eduardo Torroja
CONSEJO SUPERIOR DE INVESTIGACIONES CIENTÍFICAS

C/ Serrano Galvache n.º 4. 28033 Madrid.
Tel: (+34) 91 302 04 40 Fax. (+34) 91 302 07 00
www.ietcc.csic.es



On behalf of the Instituto de Ciencias de la Construcción Eduardo Torroja

Madrid, 27th of July 2017

Marta Mª Castellote Armero
Director

Product and installed condition

MTP, MTP-G, MTP-X anchor



Identification on anchor:

- Expansion clip:
 - Anchor MTP: Company logo + "MTP" + Metric.
 - Anchor MTP-G: Company logo + "MTP-G" + Metric.
 - Anchor MTP-X: Company logo + "MTP-X" + Metric.
- Anchor body: Metric x Length
- Blue ring mark to show embedment depth
- Length letter code on head:

Letter on head	Length [mm]
C	68 ÷ 75
D	76 ÷ 88
E	89 ÷ 101
F	102 ÷ 113
G	114 ÷ 126
H	127 ÷ 139

Letter on head	Length [mm]
I	140 ÷ 151
J	152 ÷ 164
K	165 ÷ 177
L	178 ÷ 190
M	191 ÷ 202
N	203 ÷ 215

Letter on head	Length [mm]
P	229 ÷ 240
Q	241 ÷ 253
R	254 ÷ 266
S	267 ÷ 300

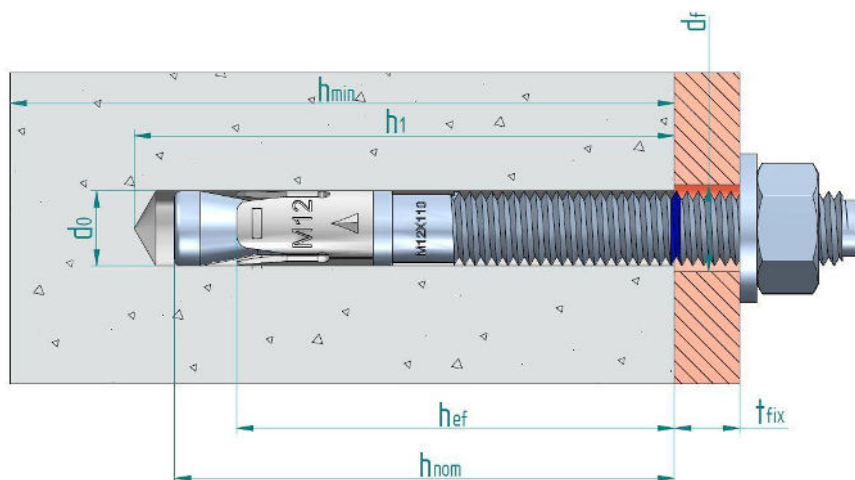

- d_0 : Nominal diameter of drill bit
- d_f : Fixture clearance hole diameter
- h_{ef} : Effective anchorage depth
- h_1 : Depth of drilled hole
- h_{nom} : Overall anchor embedment depth in the concrete
- h_{min} : Minimum thickness of concrete member
- t_{fix} : Fixture thickness

MTP, MTP-G, MTP-X anchors

Product description

Installed condition

Annex A1

English translation prepared by IETcc

Table A1: materials

Item	Designation	Material for MTP	Material for MTP-G	Material for MTP-X
1	Anchor body	M8 to M20: carbon steel wire rod, galvanized $\geq 5 \mu\text{m}$ ISO 4042 A2 with antifriction coating M24: machine carbon steel, galvanized $\geq 5 \mu\text{m}$ ISO 4042 A2 with antifriction coating	Carbon steel wire rod, sherardized $\geq 40 \mu\text{m}$ EN 13811	Carbon steel wire rod, galvanized $\geq 5 \mu\text{m}$ ISO 4042 A2 with antifriction coating
2	Washer	DIN 125, DIN 9021 galvanized $\geq 5 \mu\text{m}$ ISO 4042 A2	DIN 125, DIN 9021 sherardized $\geq 40 \mu\text{m}$ EN 13811	DIN 125, DIN 9021 galvanized $\geq 5 \mu\text{m}$ ISO 4042 A2
3	Nut	DIN 934 galvanized $\geq 5 \mu\text{m}$ ISO 4042 A2, class 6	DIN 934 sherardized $\geq 40 \mu\text{m}$ EN 13811, class 6	DIN 934 galvanized $\geq 5 \mu\text{m}$ ISO 4042 A2, class 6
4	Expansion clip	Stainless steel, grade A4	Stainless steel, grade A4	Carbon steel strip, sherardized $\geq 15 \mu\text{m}$ EN 13811

MTP, MTP-G, MTP-X anchor

Product description

Materials

Annex A2

Specifications of intended use

Anchorage subjected to:

- Static or quasi static loads
- Seismic actions:
 - for performance category C1:
 - MTP: M10, M12 and M16
 - MTP-X: M10, M12, M16 and M20
 - for performance category C2:
 - MTP: M12 and M16
 - MTP-X: M12 and M20
- Resistance to fire exposure up to 120 minutes: all versions and sizes

Base materials:

- Reinforced or unreinforced normal weight concrete according to EN 206-1:2008
- Strength classes C20/25 to C50/60 according to EN 206-1:2008
- Cracked or uncracked concrete

Use conditions (environmental conditions):

- Anchorages subjected to dry internal conditions.

Design:

- Anchorages are designed under the responsibility of an engineer experienced in anchorages and concrete.
- Verifiable calculation rules and drawings are prepared taking into account of the loads to be anchored. The position of the anchor is indicated on the design drawings (e.g. position of the anchor relative to reinforcement or to supports, etc.).
- Anchorages under static or quasi-static actions are designed for design method A in accordance with:
 - ETAG 001, Annex C, edition August 2010
 - CEN/TS 1992-4-1:2009
 - prEN1992-4
- Anchorages under seismic actions (cracked concrete) are designed in accordance with:
 - EOTA Technical Report TR 045, edition February 2013
 - prEN1992-4
 - Anchorages shall be positioned outside of critical regions (e.g. plastic hinges) of the concrete structure
 - Fastening in stand-off installation or with grout layer are not allowed.
- Anchorages under fire exposure are designed in accordance with:
 - ETAG 001, Annex C, design method A, edition August 2010 and EOTA Technical Report 020, edition May 2004
 - CEN/TS 1992-4-1:2009, annex D.
 - prEN 1992-4
 - It must be ensured that local spalling of the concrete cover does not occur.

Installation:

- Hole drilling by rotary plus hammer mode.
- Anchor installation carried out by appropriately qualified personal and under the supervision of the person responsible for technical matters of the site.
- In case of aborted hole: new drilling at a minimum distance away of twice the depth of aborted hole or smaller distance if the aborted hole is filled with high strength mortar and if under shear or oblique tension load it is not the direction of the load application.

MTP, MTP-G, MTP-X anchor	Annex B1
Intended use	
Specifications	

Table C1: Installation parameters for MTP, MTP-G, MTP-X anchor

Installation parameters			Performances					
			M8	M10	M12	M16	M20	M24
d_0	Nominal diameter of drill bit:	[mm]	8	10	12	16	20	24
d_f	Fixture clearance hole diameter:	[mm]	9	12	14	18	22	26
T_{inst}	Nominal installation torque:	[Nm]	20/15 ¹⁾	40	60	100	200	250
L_{min}	Total length of the bolt:	[mm]	68	82	98	119	140	175
L_{max}		[mm]	200	200	250	250	300	400
h_{min}	Minimum thickness of concrete member:	[mm]	100	120	140	170	200	250
h_1	Depth of drilled hole:	[mm]	60	75	85	105	125	155
h_{nom}	Overall anchor embedment depth in the concrete:	[mm]	55	68	80	97	114	143
h_{ef}	Effective anchorage depth:	[mm]	48	60	70	85	100	125
t_{fix}	Thickness of fixture ²⁾ :	[mm]	L - 66	L - 80	L - 96	L - 117	L - 138	L - 170
s_{min}	Minimum allowable spacing:	[mm]	50	60	70	85/128 ¹⁾	100/150 ¹⁾	125
c_{min}	Minimum allowable distance:	[mm]	50	60	70	85/128 ¹⁾	100/150 ¹⁾	125

¹⁾ Respective values for anchors MTP / MTP-G, MTP-X

²⁾ L = total anchor length

Installation process

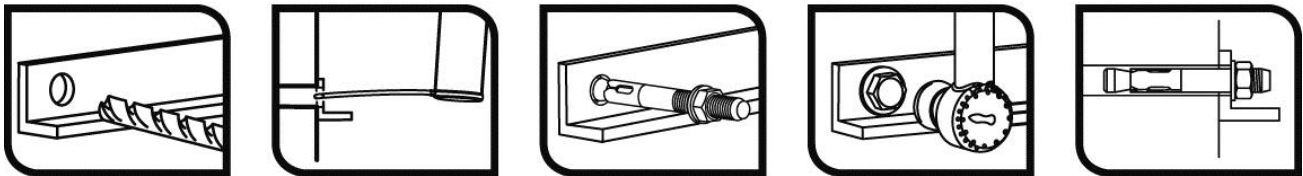

MTP, MTP-G, MTP-X anchor

Performances

Installation parameters and installation procedure

Annex C1

Table C2: Characteristic values to tension loads of design method A according to ETAG 001, Annex C, CEN/TS 1992-4 or prEN1992-4 for MTP, MTP-G, MTP-X anchor

Characteristic values of resistance to tension loads of design according to design method A		Performances							
		M8	M10	M12	M16	M20	M24		
Tension loads: steel failure									
$N_{Rk,s}$	Characteristic resistance:	[kN]	18.1	31.4	40.4	72.7	116.6	179.2	
γ_{Ms}	Partial safety factor:	[-]	1.5	1.5	1.5	1.5	1.5	1.5	
Tension loads: pull-out failure in concrete									
MTP anchor									
$N_{Rk,p,ucr}$	Characteristic resistance in C20/25 uncracked concrete:	[kN]	9	16	20	35	50	50	
$N_{Rk,p,cr}$	Characteristic resistance in C20/25 cracked concrete:	[kN]	5	9	12	25	30	30	
MTP-G anchor									
$N_{Rk,p,ucr}$	Characteristic resistance in C20/25 uncracked concrete:	[kN]	9	16	30	35	50	--	
$N_{Rk,p,cr}$	Characteristic resistance in C20/25 cracked concrete:	[kN]	6	9	16	25	30	--	
MTP-X anchor									
$N_{Rk,p,ucr}$	Characteristic resistance in C20/25 uncracked concrete:	[kN]	9	16	25	35	50	--	
$N_{Rk,p,cr}$	Characteristic resistance in C20/25 cracked concrete:	[kN]	6	9	16	25	30	--	
$\gamma_{ins}^{1)}$ $\gamma_2^{2)}$	Installation safety factor:	[-]	1.2	1.0	1.0	1.0	1.0	1.2	
ψ_c	Increasing factor for $N_{Rk,p}^0$:	C30/37	[-]	1.22	1.16	1.22	1.22	1.16	1.22
		C40/50	[-]	1.41	1.31	1.41	1.41	1.31	1.41
		C50/60	[-]	1.55	1.41	1.55	1.55	1.41	1.55
Tension loads: concrete cone and splitting failure									
h_{ef}	Effective embedment depth:	[mm]	48	60	70	85	100	125	
$k_{ucr,N}^{1)}$	Factor for uncracked concrete:	[-]	11.0						
$k_{cr,N}^{1)}$	Factor for cracked concrete:	[-]	7,7						
$k_{ucr,N}^{2)}$	Factor for uncracked concrete:	[-]	10.1						
$k_{cr,N}^{2)}$	Factor for cracked concrete:	[-]	7,2						
$\gamma_{ins}^{1)}$ $\gamma_2^{2)}$	Installation safety factor:	[-]	1.2	1.0	1.0	1.0	1.0	1.2	
$S_{cr,N}$	Concrete cone failure:	[mm]	3 x h_{ef}						
$C_{cr,N}$		[mm]	1.5 x h_{ef}						
$S_{cr,sp}$	Splitting failure:	[mm]	288	300	350	425/510 ³⁾	500/600 ³⁾	560	
$C_{cr,sp}$		[mm]	144	150	175	213/255 ³⁾	250/300 ³⁾	280	

¹⁾ Parameter relevant only for design according to CEN/TS 1992-4:2009, prEN 1992-4

²⁾ Parameter relevant only for design according to ETAG 001, Annex C

³⁾ Respective values for anchors MTP / MTP-G, MTP-X

MTP, MTP-G, MTP-X anchor	Annex C2
Performances	
Characteristic values for tension loads	

English translation prepared by IETcc

Table C3: Characteristic values to shear loads of design method A according to ETAG 001, Annex C, CEN/TS 1992-4 or prEN1992-4 for MTP, MTP-G, MTP-X anchor

Characteristic values of resistance to shear loads of design according to design method A			Performances					
			M8	M10	M12	M16	M20	M24
Shear loads: steel failure without lever arm								
$V_{Rk,s}$	Characteristic resistance:	[kN]	11.0	17.4	25.3	47.1	73.1	84.7
$k_2^{1)}$	k_2 factor:	[-]	1.0					
$k_7^{2)}$	k_7 factor:	[-]	1.0					
γ_{Ms}	Partial safety factor:	[-]	1.25	1.25	1.25	1.25	1.25	1.25
Shear loads: steel failure with lever arm								
$M_{Rk,s}^0$	Characteristic bending moment:	[Nm]	22.5	44.8	78.6	199.8	389.4	673.5
γ_{Ms}	Partial safety factor:	[-]	1.25	1.25	1.25	1.25	1.25	1.25
Shear loads: concrete pryout failure								
$k_3^{1)} = k_8^{2)}$ $k^{3)}$	k factor:	[-]	1	2	2	2	2	2
$\gamma_{ins}^{1) 2)}$ $\gamma_2^{3)}$	Installation safety factor:	[-]	1.0					
Shear loads: concrete edge failure								
l_f	Effective length of anchor under shear loads:	[mm]	48	60	70	85	100	125
d_{nom}	Outside anchor diameter:	[mm]	8	10	12	16	20	24
$\gamma_{ins}^{1) 2)}$ $\gamma_2^{3)}$	Installation safety factor:	[-]	1.0					

¹⁾ Parameter relevant only for design according to CEN/TS 1992-4:2009

²⁾ Parameter relevant only for design according to prEN 1992-4

³⁾ Parameter relevant only for design according to ETAG 001, Annex C

MTP, MTP-G, MTP-X anchor

Performances

Characteristic values for shear load.

Annex C3

Table C4: Displacements under tension load for MTP, MTP-G, MTP-X anchor

Displacements under tension loads			Performances					
			M8	M10	M12	M16	M20	M24
MTP anchor								
N	Service tension load:	[kN]	2.5	4.3	6.3	10.4	13.9	18.0
$\bar{\delta}_{N0}$	Short term displacement:	[mm]	1.1	0.7	1.0	0.4	1.6	0.4
$\bar{\delta}_{N\infty}$	Long term displacement:	[mm]	1.9	1.9	1.9	1.9	1.9	2.0
MTP-G anchor								
N	Service tension load:	[kN]	2.5	4.3	6.3	10.4	13.9	--
$\bar{\delta}_{N0}$	Short term displacement:	[mm]	1.0	1.1	0.9	1.5	1.2	--
$\bar{\delta}_{N\infty}$	Long term displacement:	[mm]	1.9	1.9	1.9	1.9	1.9	--
MTP-X anchor								
N	Service tension load:	[kN]	2.5	4.3	7.6	11.9	14.3	--
$\bar{\delta}_{N0}$	Short term displacement:	[mm]	1.0	1.1	0.9	1.5	1.3	--
$\bar{\delta}_{N\infty}$	Long term displacement:	[mm]	1.6	1.6	1.6	1.6	1.6	--

Table C5: Displacements under shear load for MTP, MTP-G, MTP-X anchor

Displacements under shear loads			Performances					
			M8	M10	M12	M16	M20	M24
MTP anchor								
V	Service shear load:	[kN]	4.9	6.8	8.5	15.1	24.6	33.6
$\bar{\delta}_{V0}$	Short term displacement:	[mm]	1.0	1.5	1.8	1.9	3.1	1.4
$\bar{\delta}_{V\infty}$	Long term displacement:	[mm]	1.5	2.3	2.7	2.9	4.7	2.1
MTP-G anchor								
V	Service shear load:	[kN]	4.9	6.8	8.5	15.1	24.6	-
$\bar{\delta}_{V0}$	Short term displacement:	[mm]	1.0	1.5	1.8	1.9	3.1	--
$\bar{\delta}_{V\infty}$	Long term displacement:	[mm]	1.5	2.3	2.7	2.9	4.7	--
MTP-X anchor								
V	Service shear load:	[kN]	4.9	6.8	8.5	15.1	24.6	--
$\bar{\delta}_{V0}$	Short term displacement:	[mm]	1.0	1.5	1.8	1.9	3.1	--
$\bar{\delta}_{V\infty}$	Long term displacement:	[mm]	1.5	2.3	2.7	2.9	4.7	--

MTP, MTP-G, MTP-X anchor

Performances

Displacements under tension and shear loads

Annex C4

English translation prepared by IETcc

Table C6: Design information for seismic performance C1 MTP, MTP-X anchor

Design information for seismic performance C1			Performances					
			M8	M10	M12	M16	M20	M24
Steel failure for tension and shear failure								
$N_{Rk,s,seis}$	Characteristic tension steel failure:	[kN]	--	31.4	40.4	72.7	116.6	--
$\gamma_{Ms,N}$	Partial safety factor:	[-]	--	1.5	1.5	1.5	1.5	--
$V_{Rk,p,seis}$	Characteristic shear steel failure:	[kN]	--	12.2	17.8	33.0	58.5	--
$\gamma_{Ms,V}$	Partial safety factor:	[-]	--	1.25	1.25	1.25	1.25	--
Pull out failure								
MTP anchor								
$N_{Rk,p,seis}$	Characteristic pull out failure:	[kN]	--	5.3	8.4	17.5	--	--
MTP-X anchor								
$N_{Rk,p,seis}$	Characteristic pull out failure:	[kN]	--	3.9	16.0	25.0	30.0	--
$\gamma_{ins}^{1)}$ $\gamma_2^{2)}$	Installation safety factor:	[-]	--	1.0	1.0	1.0	1.0	--
Concrete cone failure								
h_{ef}	Effective embedment depth:	[mm]	--	60	70	85	100	--
$s_{cr,N}$	Spacing:	[mm]	--	3 x h_{ef}				--
$c_{cr,N}$	Edge distance:	[mm]	--	1.5 x h_{ef}				--
$\gamma_{ins}^{1)}$ $\gamma_2^{2)}$	Installation safety factor:	[-]	--	1.0	1.0	1.0	1.0	--
Concrete pryout failure								
$k_3^{1)}$ $k_2^{2)}$	k factor:	[-]	--	2	2	2	2	--
Concrete edge failure								
l_f	Effective length of anchor:	[kN]	--	60	70	85	100	--
d_{nom}	Outside anchor diameter:	[-]	--	10	12	16	20	--

¹⁾ Parameter relevant only for design according to CEN/TS 1992-4:2009, prEN 1992-4

²⁾ Parameter relevant only for design according to ETAG 001, Annex C

MTP, MTP-X anchor	Annex C5
Performances	
Design information for seismic performance C1	

Table C7: Design information for seismic performance C2 MTP, MTP-X anchor

Design information for seismic performance C2			Performances					
			M8	M10	M12	M16	M20	M24
Steel failure for tension and shear failure								
$N_{Rk,s,seis}$	Characteristic tension steel failure:	[kN]	--	--	40.4	72.7	116.6	--
$\gamma_{Ms,N}$	Partial safety factor:	[-]	--	--	1.5	1.5	1.5	--
$V_{Rk,p,seis}$	Characteristic shear steel failure:	[kN]	--	--	17.8	33.0	58.5	--
$\gamma_{Ms,V}$	Partial safety factor:	[-]	--	--	1.25	1.25	1.25	--
Pull out failure								
MTP anchor								
$N_{Rk,p,seis}$	Characteristic pull out failure:	[kN]	--	--	5.2	8.9	--	--
MTP-X anchor								
$N_{Rk,p,seis}$	Characteristic pull out failure:	[kN]	--	--	9.1	--	21.0	--
$\gamma_{ins}^{1)}$ $\gamma_2^{2)}$	Installation safety factor:	[-]	--	--	1.0	1.0	1.0	--
Concrete cone failure								
h_{ef}	Effective embedment depth:	[mm]	--	--	70	85	100	--
$s_{cr,N}$	Spacing:	[mm]	--	--	3 x h_{ef}			--
$c_{cr,N}$	Edge distance:	[mm]	--	--	1.5 x h_{ef}			--
$\gamma_{ins}^{1)}$ $\gamma_2^{2)}$	Installation safety factor:	[-]	--	--	1.0	1.0	1.0	--
Concrete pryout failure								
$k_3^{1)}$ $k^{2)}$	k factor:	[-]	--	--	2	2	2	--
Concrete edge failure								
l_f	Effective length of anchor:	[kN]	--	--	70	85	100	--
d_{nom}	Outside anchor diameter:	[-]	--	--	12	16	20	--
Displacements								
MTP anchor								
$\bar{O}_{N,seis} (DLS)$	Displacement Damage Limitation State: ^{3) 4)}	[mm]	--	--	2.34	3.99	--	--
$\bar{O}_{V,seis} (DLS)$		[mm]	--	--	5.53	5.96	--	--
$\bar{O}_{N,seis} (ULS)$	Displacement Ultimate Limit State: ³⁾	[mm]	--	--	9.54	10.17	--	--
$\bar{O}_{V,seis} (ULS)$		[mm]	--	--	9.08	10.66	--	--
MTP-X anchor								
$\bar{O}_{N,seis} (DLS)$	Displacement Damage Limitation State: ^{3) 4)}	[mm]	--	--	5.57	--	6.82	--
$\bar{O}_{V,seis} (DLS)$		[mm]	--	--	5.53	--	6.37	--
$\bar{O}_{N,seis} (ULS)$	Displacement Ultimate Limit State: ³⁾	[mm]	--	--	20.31	--	29.12	--
$\bar{O}_{V,seis} (ULS)$		[mm]	--	--	9.08	--	12.32	--

¹⁾ Parameter relevant only for design according to CEN/TS 1992-4:2009, prEN 1992-4

²⁾ Parameter relevant only for design according to ETAG 001, Annex C

³⁾ The listed displacements represent mean values

⁴⁾ A small displacement may be required in the design in the case of displacements sensitive fastening of "rigid" supports. The characteristics resistance associated with such small displacements may be determined by linear interpolation or proportional reduction.

MTP, MTP-X anchor

Performances

Design information for seismic performance C2

Annex C6

Table C8: Characteristic values for resistance to fire MTP, MTP-G, MTP-X anchor

Characteristic values for resistance to fire			Performances					
			M8	M10	M12	M16	M20	M24
Steel failure								
$N_{Rk,s,fi}$	Characteristic tension resistance:	R30 [kN]	0,4	0,9	1,7	3,1	4,9	7,1
		R60 [kN]	0,3	0,8	1,3	2,4	3,7	5,3
		R90 [kN]	0,3	0,6	1,1	2,0	3,2	4,6
		R120 [kN]	0,2	0,5	0,8	1,6	2,5	3,5
$V_{Rk,s,fi}$	Characteristic shear resistance:	R30 [kN]	0,4	0,9	1,7	3,1	4,9	7,1
		R60 [kN]	0,3	0,8	1,3	2,4	3,7	5,3
		R90 [kN]	0,3	0,6	1,1	2,0	3,2	4,5
		R120 [kN]	0,2	0,5	0,8	1,6	2,5	3,5
$M^0_{Rk,s,fi}$	Characteristic bending resistance:	R30 [kN]	0,4	1,1	2,6	6,7	13,0	22,5
		R60 [kN]	0,3	1,0	2,0	5,0	9,7	16,8
		R90 [kN]	0,3	0,7	1,7	4,3	8,4	14,6
		R120 [kN]	0,2	0,6	1,3	3,3	6,5	11,2
Pull out failure								
$N_{Rk,p,fi}$	Characteristic resistance:	R30 [kN]						
		R60 [kN]	1,3/1,5 ³⁾	2,3	3,0/4,0 ³⁾	6,3	7,5	7,5
		R90 [kN]						
		R120 [kN]	1,0/1,2 ³⁾	1,8	2,4/3,2 ³⁾	5,0	6,0	6,0
Concrete cone failure ⁴⁾								
$N_{Rk,p,fi}$	Characteristic resistance:	R30 [kN]						
		R60 [kN]	2,9	5,0	7,4	12,0	18,0	31,4
		R90 [kN]						
		R120 [kN]	2,3	4,0	5,9	9,6	14,4	25,2
$s_{cr,N,fi}$	Critical spacing:	R30 to R120 [mm]	4 x h_{ef}					
$s_{min,fi}$	Minimum spacing:	R30 to R120 [mm]	50	60	70	85/128 ³⁾	100/150 ³⁾	125
$c_{cr,N,fi}$	Critical edge distance:	R30 to R120 [mm]	2 x h_{ef}					
$c_{min,fi}$	Minimum edge distance:	R30 to R120 [mm]	$c_{min} = 2 \times h_{ef}$; if fire attack comes from more than one side, the edge distance of the anchor has to be ≥ 300 mm and $\geq 2 \times h_{ef}$					
Concrete pry out failure								
$k_3^{1)}$ $k^{2)}$	k factor:	R30 to R120 [-]	1	2	2	2	2	2

¹⁾ Parameter relevant only for design according to CEN/TS 1992-4:2009, prEN 1992-4

²⁾ Parameter relevant only for design according to ETAG 001, Annex C

³⁾ Respective values for anchors MTP / MTP-G, MTP-X

⁴⁾ As a rule, splitting failure can be neglected since cracked concrete and reinforcement is assumed.

Remark: In absence of other national regulations the partial safety factor for resistance under fire exposure $\gamma_{m,fi} = 1,0$ is recommended

MTP, MTP-G, MTP-X anchor

Performances

Characteristic values for resistance to fire

Annex C7