



ETA-Danmark A/S  
Göteborg Plads 1  
DK-2150 Nordhavn  
Tel. +45 72 24 59 00  
Fax +45 72 24 59 04  
Internet [www.etadanmark.dk](http://www.etadanmark.dk)

Authorized and notified according  
to Article 29 of the Regulation (EU)  
No 305/2011 of the European  
Parliament and of the Council of 9  
March 2011

MEMBER OF EOTA



## European Technical Assessment ETA-17/0468 of 30/08/2017

### General Part

#### Technical Assessment Body issuing the ETA and designated according to Article 29 of the Regulation (EU) No 305/2011: ETA-Danmark A/S

Trade name of the  
construction product:

FLAMRO FM I Kombischott EN

Product family to which the  
above construction product  
belongs:

Mortar products for fire sealing and fire stopping  
purposes.

Manufacturer:

Flamro Brandschutz- Systeme GmbH  
Am Sportplatz 2  
DE-56291 Leiningen  
Tel. + 49 6746 9410 - 0  
Fax +49 6746 9410 - 10  
Internet [www.flamro.de](http://www.flamro.de)

Manufacturing plant:

Flamro Brandschutz- Systeme GmbH  
Am Sportplatz 2  
DE-56291 Leiningen

This European Technical  
Assessment contains:

28 pages including 5 annex which form an integral part  
of the document

This European Technical  
Assessment is issued in  
accordance with Regulation  
(EU) No 305/2011, on the  
basis of:

Guideline for European technical approval of "*Fire  
Stopping and Fire Sealing Products*", ETAG 026 Part 2:  
"*Penetration Seals*", used as European Assessment  
Document (EAD) according to Article 66 Paragraph 3 of  
Regulation (EU) No 305/2011.

This version replaces:

-

Translations of this European Technical Assessment in other languages shall fully correspond to the original issued document and should be identified as such.

Communication of this European Technical Assessment, including transmission by electronic means, shall be in full (excepted the confidential Annex(es) referred to above). However, partial reproduction may be made, with the written consent of the issuing Technical Assessment Body. Any partial reproduction has to be identified as such.

## II SPECIFIC PART OF THE EUROPEAN TECHNICAL ASSESSMENT

### 1 Technical description of product and intended use

#### Technical description of the product

The main component of the system is the fire protection mortar, which consist of a grey powder of dry cement and lime mineral construction material, binder, aggregates and additives (Cement, Portland, chemicals) A mixture of 20 kg dry mortar plus 6 liters of water results in approximately 20 liters ready to use wet mortar. The ready mixed mortar, mixed with water has a strong alkaline reaction and should be applied with a trowel or pump and then compacted. Make sure that gaps, voids and remaining openings are completely closed and sealed. Smooth the surface like ordinary concrete.

FLAMRO FM I Kombischott EN shall be installed in openings in fire classified rigid floor slabs made from concrete, aerated concrete or masonry structures with a minimum thickness of 150 [mm]. In the event of a fire, the fire protection cable mortar cast flush with the floor slab within an opening gap of maximum 1200 x 1000 [mm] (length x width). Will be intended to temporarily or permanently firestop penetrations passing through fire-rated constructions.

FLAMRO FM I Kombischott EN shall be installed in openings in fire classified rigid walls made from concrete, aerated concrete or masonry structures with a minimum thickness of 100 [mm] plus 2 x 35 [mm] Promatect plates. In the event of a fire, the fire protection cable mortar cast flush with the rigid wall within an opening gap of maximum 1200 x 2000 [mm] and/or 1200 x 1500 [mm] (length x width). Will be intended to temporarily or permanently firestop penetrations passing through fire-rated constructions.

Detailed specifications for identification and performance criteria relevant for fire safety with regard to the construction products are given in Annex 1-5.

#### Specification of the intended use in accordance with the applicable European Assessment Document

The construction products FLAMRO FM I Kombischott EN is assessed to provide fire protection to services, single cables, cable groups, cable trays as well as combustible and non- combustible pipes passing through floors and walls.

Table 1 – components of the verified penetration seals

Product type	Trade name
Mortar for fire protection around cables	FLAMRO FM I

Detailed information and data on the verified penetration seals are given in Annex 1.

Additional protections are:

- FLAMRO FM I (Mortar)
- FLAMRO Variant N II A (Pipe collar)
- FLAMRO Variant N III wrap (Pipe collar)
- BC Brandschutz coating (FLAMRO)
- FLAMRO BaGe - KVB
- Insulation mat Klimarock (Rockwool)
- Insulation shell Armaflex Protect (Armacell). In services: cables, waveguides, cable trays and ladders, steel, copper PVC-U, PEHD, PE and PP pipes and FFKuS-EM-F Highspeed conduits (full and empty)

The performances given in Section 3 exclusively relate to this penetration seals (e.g. with respect to the design and arrangement of the components of the penetration seals and the type and position of the services, see annex 1-5).

The verification and assessment methods on which this European Technical Assessment is based, lead to the assumption of a working life for FLAMRO FM I Kombischott EN of at least 10 years.

The indications given on the working life cannot be interpreted as a guarantee given by the manufacturer, but are to be regarded only as a means for choosing the right product in relation to the expected economically reasonable working life of the works.

### 3 Performance of the product and references to the methods used for its assessment

Characteristic	Assessment of characteristic
<b>3.2 Safety in case of fire (ER 2)</b>	
Reaction to fire	<b>NPA</b> (No Performance Assessed)
Resistance to fire	FLAMRO FM I Kombischott EN used as described in annex 1, 2 and 3 in minimum 150 [mm] thick floor slab made from aerated concrete structures is classified as <b>EI 60-120</b> in accordance with EN 13501-2  FLAMRO FM I Kombischott EN used as described in annex 1, 4 and 5 in minimum 100 [mm] plus 2 x 35 [mm] Promatect plates thick rigid wall made from aerated concrete structures is classified as <b>EI 90-120</b> in accordance with EN 13501-2.

### 3.3 Hygiene, health and the environment (ER 3)

Release of dangerous substances\*)

FLAMRO FM I cable mortar does live up to the “Emissions-Anforderungen” **Klasse A+** according to the decrets Nr. 2011-321 dated 2011-03-23.

The product also fulfils the “Emissions-Anforderungen” AgBB-schemes.

In addition to the specific clauses relating to dangerous substances contained in this European Technical Assessment, there may be other requirements applicable to the products falling within its scope (e.g. transposed European legislation and national laws, regulations and administrative provisions). In order to meet the provisions of the Construction Products Regulation, these requirements need also to be complied with, when and where they apply.

\*) In addition to the specific clauses relating to dangerous substances contained in this European technical Assessment, there may be other requirements applicable to the products falling within its scope (e.g. transposed European legislation and national laws, regulations and administrative provisions). In order to meet the provisions of the Construction Products Regulation, these requirements need also to be complied with, when and where they apply.

### 3.9 General aspects relating to fitness for use (ER 6)

#### Durability and serviceability:

The verification of durability is part of testing the essential requirements. FLAMRO FM I Kombischott may be used in end-use applications according to the provisions for category X without expecting significant changes of the characteristics relevant for fire sealing and fire stopping properties and the result performance.

The proof and its assessment concerning applicability under climate conditions were carried out in accordance with EOTA TR 024 clause 4.2.

Property	Parameter	Method
Appearance	Visually examined OK	B.12
Compressive strength fully dried normal conditions after: 77 days	5,1 [N/mm <sup>2</sup> ] + max 15 [%] ≈ 5,9 [N/mm <sup>2</sup> ] OK	B.5.1.1 in accordance with EN1015-11
Compressive strength after conditioning: 77 days	5,9 [N/mm <sup>2</sup> ]	B.5.1.2 in accordance with EN1015-11

## **4 Assessment and verification of constancy of performance (AVCP)**

### **4.1 AVCP system**

According to the decision 1999/454/EC of the European Commission, as amended by 2001/596/EC, the system(s) of assessment and verification of constancy of performance (see Annex V to Regulation (EU) No 305/2011) is 1.

## **5 Technical details necessary for the implementation of the AVCP system, as foreseen in the applicable EAD**

Technical details necessary for the implementation of the AVCP system are laid down in the control plan deposited at ETA-Danmark prior to CE marking.

Issued in Copenhagen on 2017-08-30 by



Thomas Bruun  
Managing Director, ETA-Danmark

**Annex 1**  
**Product details, definitions and specification of intended use**

FLAMRO FM I Kombischott EN

The product specification details of the FLAMRO FM I Kombischott EN:

<b>Manufacturer</b>		<b>Description</b>
Flamro Brandschutz- Systeme GmbH Am Sportplatz 2 DE-56291 Leiningen		FLAMRO FM I Kombischott EN
<b>Property</b>	<b>Parameter</b>	<b>Method</b>
Dry density	905[kg/m <sup>3</sup> ]	EN 1015
Flexural strength	1,2 [N/mm <sup>2</sup> ]	EN 1015
Appearance	Visually examined OK	B.12
Compressive strength after: 3 days 7 days 28 days	1,9 [N/mm <sup>2</sup> ] 4,9 [N/mm <sup>2</sup> ] 7,2 [N/mm <sup>2</sup> ]	B.5.1.1 in accordance with EN1015-11
Compressive strength fully dried normal conditions after: 77 days	5,1 [N/mm <sup>2</sup> ]	B.5.1.1 in accordance with EN1015-11
Compressive strength after conditioning: 77 days	5,9 [N/mm <sup>2</sup> ]	B.5.1.2 in accordance with EN1015-11
Dimensions of void	Thickness minimum 150 [mm] (floor) Opening gap, 1200x1000 [mm] (length x width)  Thickness minimum 100 [mm] plus 2 x 35 [mm] Promatect plates (wall) Opening gap, 1200x2000 [mm] (length x width) or Opening gap, 1200x1500 [mm] (length x width)	

The definition of the intended use of FLAMRO FM I Kombischott EN. The fire protection cable mortar is intended to be used to temporarily or permanently firestop penetrations passing through fire-rated rigid wall constructions and rigid floor constructions and reinstate the fire resistance performance of the penetrated construction. FLAMRO FM I Kombischott EN can be installed only in the types of separating elements as specified in the following table.

<b>Separating element</b>	<b>Construction</b>
Rigid walls	<ul style="list-style-type: none"> <li>• Aerated concrete, concrete, masonry</li> <li>• Minimum density 550 kg/m<sup>3</sup></li> <li>• Minimum thickness 100 [mm] plus 2 x 35 [mm] Promatect plates</li> <li>• The rigid wall shall be classified in accordance with EN 13501 – 2 for the required fire resistance period.</li> </ul>
Rigid floors	<ul style="list-style-type: none"> <li>• Aerated concrete, concrete, masonry</li> <li>• Minimum density 650 kg/m<sup>3</sup></li> <li>• Minimum thickness 150 mm</li> <li>• The rigid wall shall be classified in accordance with EN 13501 – 2 for the required fire resistance period.</li> </ul>

## Annex 2

### Description of the test conditions for the rigid 150 mm floor slab, under which the fire resistance performance was determined regarding FLAMRO FM I Kombischott EN

The test was performed on a test specimen placed in an aerated concrete slab floor of 150 [mm] thickness including an opening gap. The opening is filled with FLAMRO FM I Kombischott EN penetration sealing system. All the results and information is extracted on the grounds of the standard EN 1366-3: 2009. The below applies to seals in 150[mm] thick concrete floor slab with the following specifications:

- The concrete floor slab shall be classified according to EN 13501-2
- The floor shall be at least 150 mm thick
- The floor shall be made from concrete or aerated concrete with a density of at least 650 kg/m<sup>3</sup>
- The service support construction was consisting of:
  - Fixing planes and base plate C41/41/2,5
  - Screws + nuts M10 x 30/60/80/100 mm
- Each pipe was supported by one level of fixing planes which must be positioned at:
  - 500 [mm] from the penetration on the unexposed side for the plastic pipes equipped with FLAMRO VARIANT N II A, FLAMRO VARIANT N III wrap.
  - 650 [mm] from the penetration on the unexposed side for the steel pipes.
- FLAMRO BaGe - KVB must be fixed by metallic clamps and applied around the cable trays, ladders and cables on both sides.
- BC Brandschutz coating applied around the cable trays, ladders and cables on both sides.
- Closing of cables and conduits at their ends with BC-Brandschutz coating.
- For steel and copper pipes, Armaflex protect shell set up at 1 m length at each side and through the penetration.
- Rockwool Klimarock mat around pipes at each side and through the penetration and FLAMRO BaGe – KVB around the Rockwool mat at the fire side of the penetration on a length of 250 mm.
- FLAMRO VARIANT N III wrap around plastic pipes through the opening and flush to the fire side:
  - For plastic pipes Ø75 mm, 2 layers of 50 x 2 mm strips are installed.
  - For plastic pipes Ø110 mm, 3 layers of 50 x 2 mm strips are installed.
- For plastic pipes the protection with collars FLAMRO VARIANT N II A around the pipes below the floor. The collars were fixed on the exposed side with M5 x 50 mm screws and washers and with metallic plug 6 x 32 mm
- For polyolefin cables and conduits bundles protection with collars FLAMRO VARIANT N II A around the pipes below the floor. The collars were fixed on the exposed side with M5 x 50 mm screws and washers and with metallic plug 6 x 32 mm
- The length of the services varies so that it is possible to have a length of the services of at least 500 [mm] on both sides of the floor and at least a length of 150 [mm] of non-protected services.
- The opening gap in the concrete floor slab must be filled with the FLAMRO FM I Kombischott EN penetration sealing system to be able to resist fire in respect of the fire performance characteristics given in clause 5 of EN 13501-2.
- The pipes shall penetrate the floor perpendicular to the floor.

The first of three tests the service layout in the opening was carried out in accordance with annex F option 1:

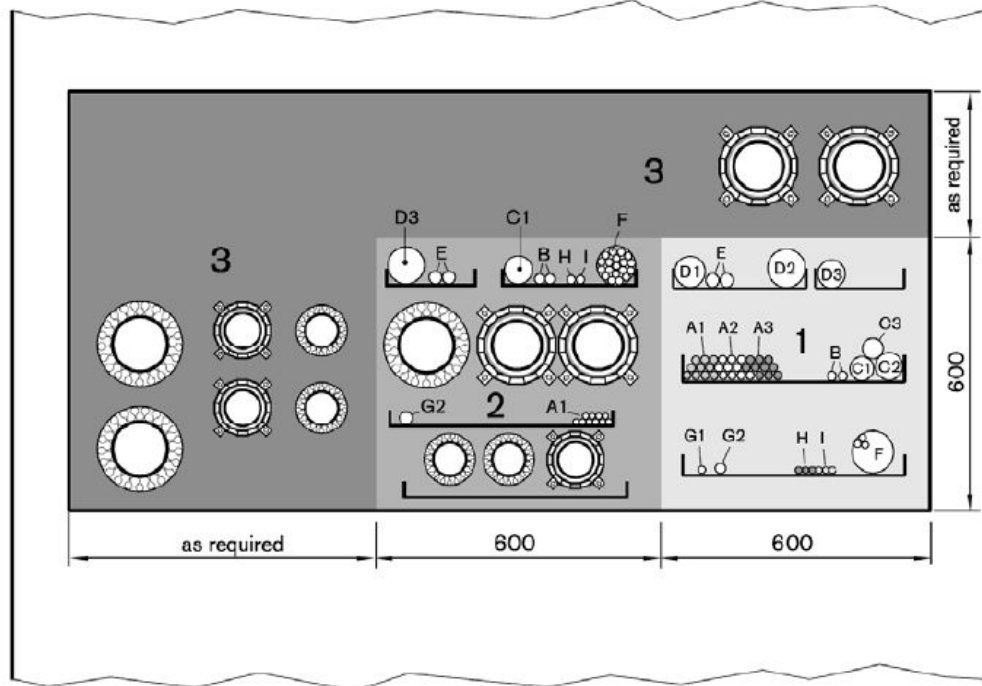

- Module 1: Standard cable module
- Module 2: Standard mixed module
- Module 3: Pipes and other services, e.g. cables pipe / conduits

The opening gap / void was filled with 150 [mm] thick FLAMRO FM I. Additional protection installed depending on the type of services.

The second of the three tests included only pipes all uncapped inside and outside the furnace:

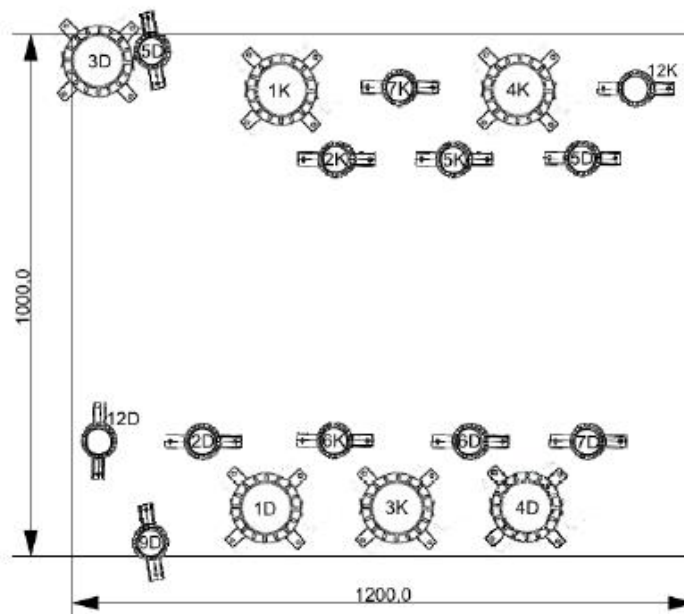

The third of the three tests, the service layout in the opening was carried out in accordance with annex F option 2:

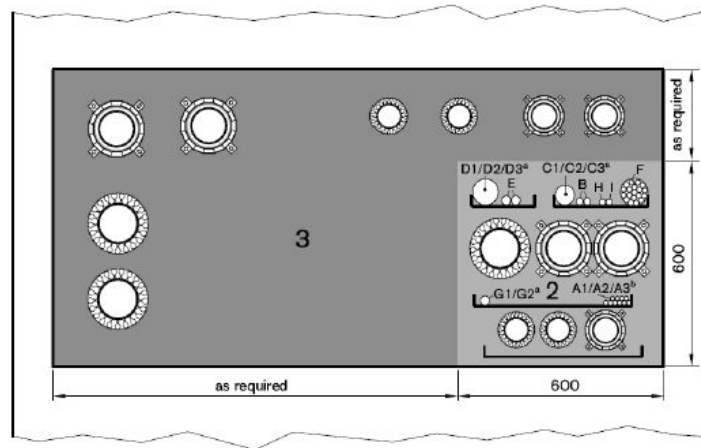

Module 2: Standard mixed module

Module 3: Pipes and other services, e.g. cables pipe / conduits

The opening gap / void was filled with 150 [mm] thick FLAMRO FM . Additional protection installed depending on the type of services.

Principal section sketches

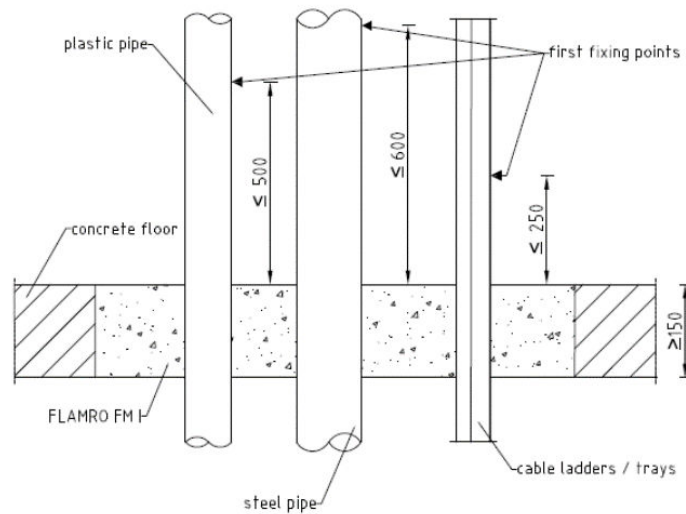

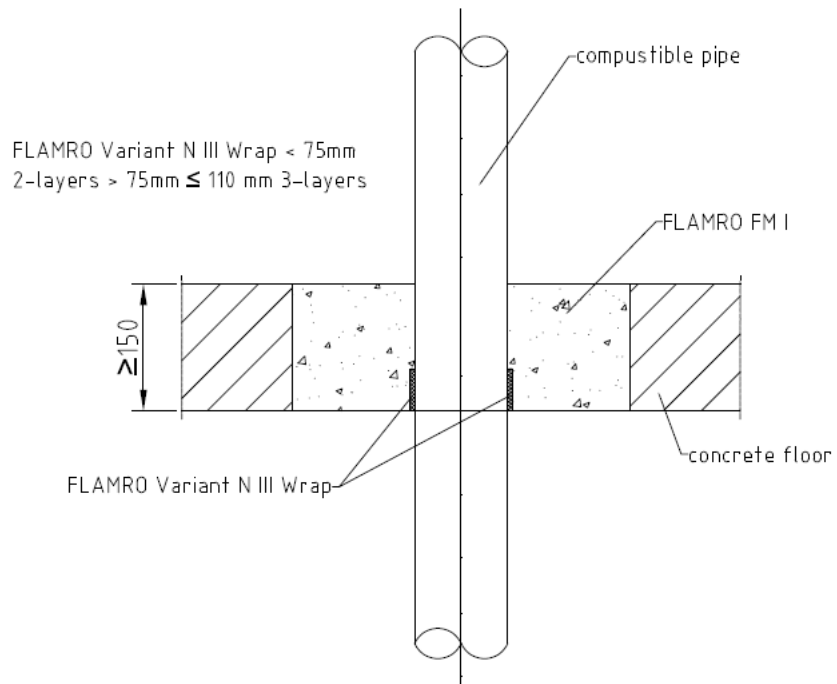
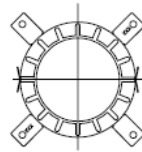
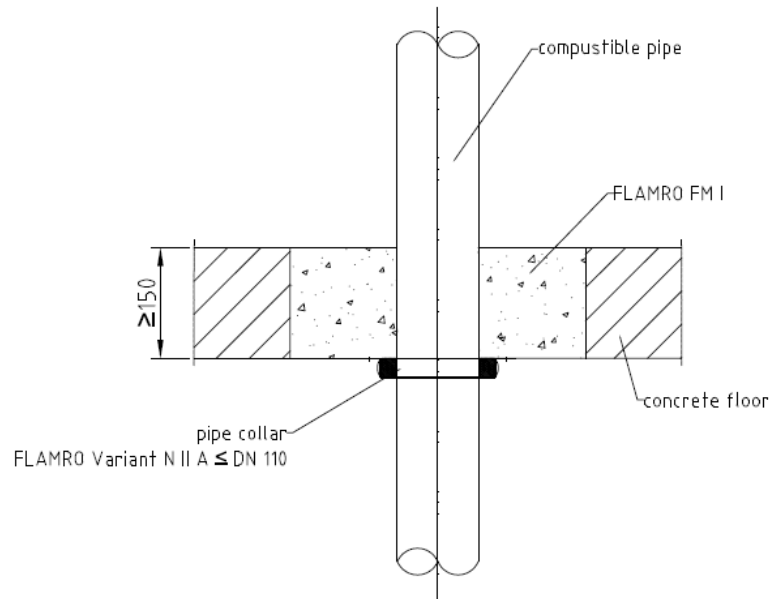

### Annex 3

#### **Description of the test conditions for the rigid 100 [mm] block wall plus 2 x 35 [mm] Promatect plates under which the fire resistance performance was determined regarding FLAMRO FM I Kombischott EN**

The test was performed on a test specimen placed in an aerated concrete block wall 100 [mm] thick plus 2 x 35 [mm] Promatect plates including opening gap. The opening is filled with the product FLAMRO FM I Fire Protection Cable Mortar penetration sealing system. All the results and information is extracted on the grounds of the standard EN 1366-3: 2009. The below applies to seals in 100 [mm] thick aerated concrete block wall plus 2 x 35 [mm] Promatect plates with the following specifications:

- The aerated concrete block wall shall be classified according to EN 13501-2
- The wall shall be made from aerated concrete blocks with a density of at least 550 kg/m<sup>3</sup>
- The wall shall be at least 100 [mm] thick aerated concrete block plus 2 x 35 [mm] Promatect. Totally 170 [mm]
- The service support construction was consisting of:
  - Fixing planes and base plate C41/41/2,5
  - Screws M6 x 70 mm + metallic plug GBD 10/6
  - Base plates fixed with nuts M10 x 30 mm
- Each pipe was supported by one level of fixing planes which must be positioned at:
  - 500 [mm] from the penetration on both ends, for metal pipes.
  - 500 [mm] from the penetration on the unexposed side for the plastic pipes.
  - 200 [mm] and 400 [mm] from the penetration on both sides. For cables ladders/trays supported by two levels of steel rods.
  - 200 [mm] from the penetration on both sides. For cables conduits supported by one level of steel rods.
- The length of the services varies so that it is possible to have a length of the services of at least 500 [mm] on both sides of the floor and at least a length of 150 [mm] of non-protected services.
- FLAMRO BaGe - KVB must be fixed by metallic clamps and applied around the cable trays, ladders and cables on both sides.
- BC Brandshutz coating applied around the cable trays, ladders and cables on both sides.
- Closing of cables and conduits at their ends with BC-Brandschutz coating.
- For steel and copper pipes, Armaflex protect shell set up at 1 m length at each side and through the penetration.
- For steel and copper pipes Rockwool Klimarock mat around pipes at each side of the penetration, for interrupted protection and fit around the pipe and fixed with steel bands or steel clap for diameter DN150. FLAMRO BaGe - KVB around the Rockwool mat at the fire side of the penetration on a length of 250 mm.
- FLAMRO VARIANT N III wrap around plastic pipes through the opening and flush to the fire side:
  - For plastic pipes Ø75 mm, 2 x 2 layers of 50 x 2 mm strips are installed.
  - For plastic pipes Ø110 mm, 2 x 3 layers of 50 x 2 mm strips are installed.
- For plastic pipes the protection with collar FLAMRO VARIANT N II A around the pipes below the floor. The collar was fixed on the exposed side with M5 x 50 mm screws and washers and with metallic plug 6 x 32 mm
- For polyolefin cables and conduits bundles protection with collar FLAMRO VARIANT N II A around the pipes below the floor. The collars were fixed on the exposed side with M5 x 50 mm screws and washers and with metallic plug 6 x 32 mm
- The opening gap in the concrete floor slab must be filled with the product FLAMRO – penetration sealing system to be able to resist fire in respect of the fire performance characteristics given in clause 5 of EN 13501-2.
- The pipes shall penetrate the wall perpendicular to the wall.

The first of two test, the service layout in the opening No1 was carried out in accordance with annex F option 1:

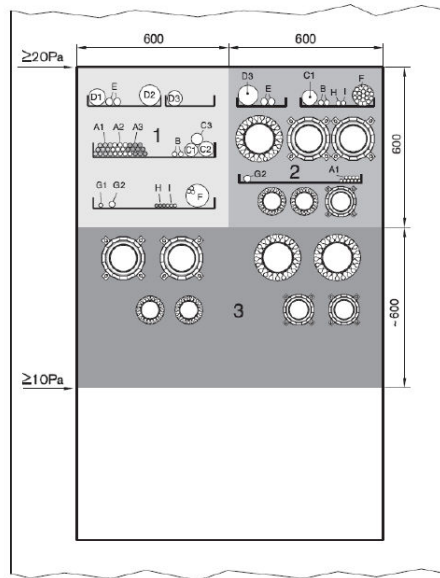

Module 1: Standard cable module

Module 2: Standard mixed module

Module 3: Pipes and other services, e.g. cables pipe / conduits

The opening gap / void was filled with 170 [mm] thick FLAMRO FM I. Additional protection installed depending on the type of services.

The services layout in the opening No2 was composed by pipes, waveguides, cables conduits bundles and cables ladders for optimisation of the cables protection length.

The second of the two test, the service layout in the opening No1 was carried out in accordance with annex F option 2:

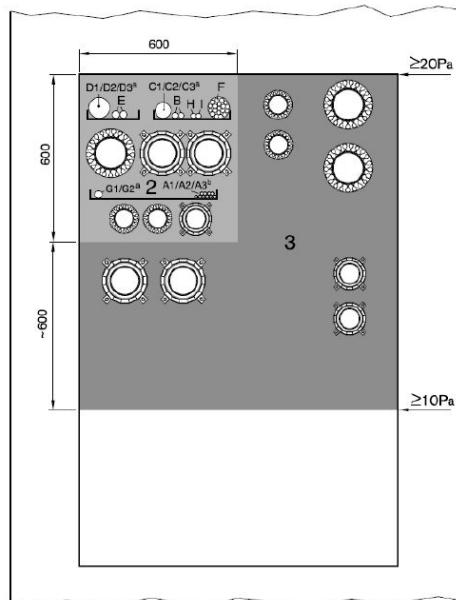

Module 2: Standard mixed module

Module 3: Pipes and other services, e.g. cables pipe / conduits

The opening gap / void was filled with 170 [mm] thick FLAMRO FM I. Additional protection installed depending on the type of services

Principal section sketches

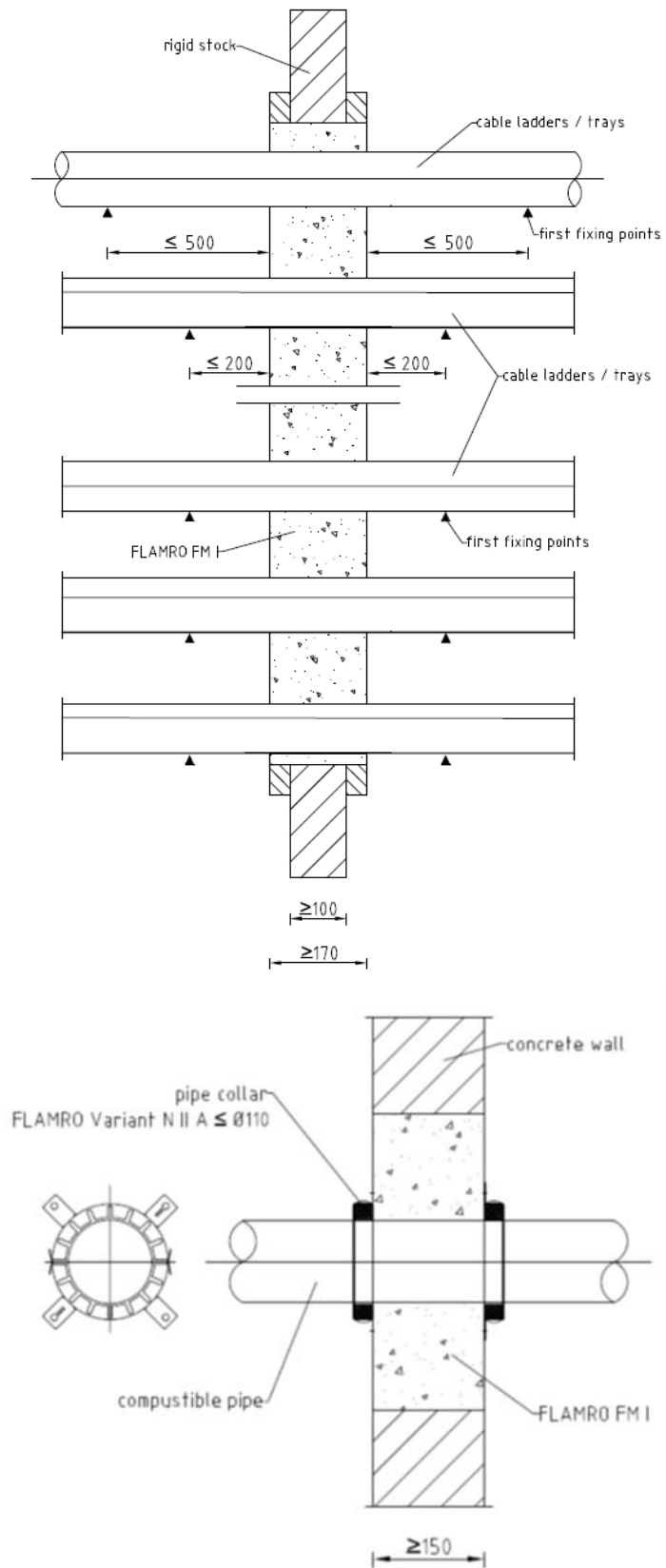

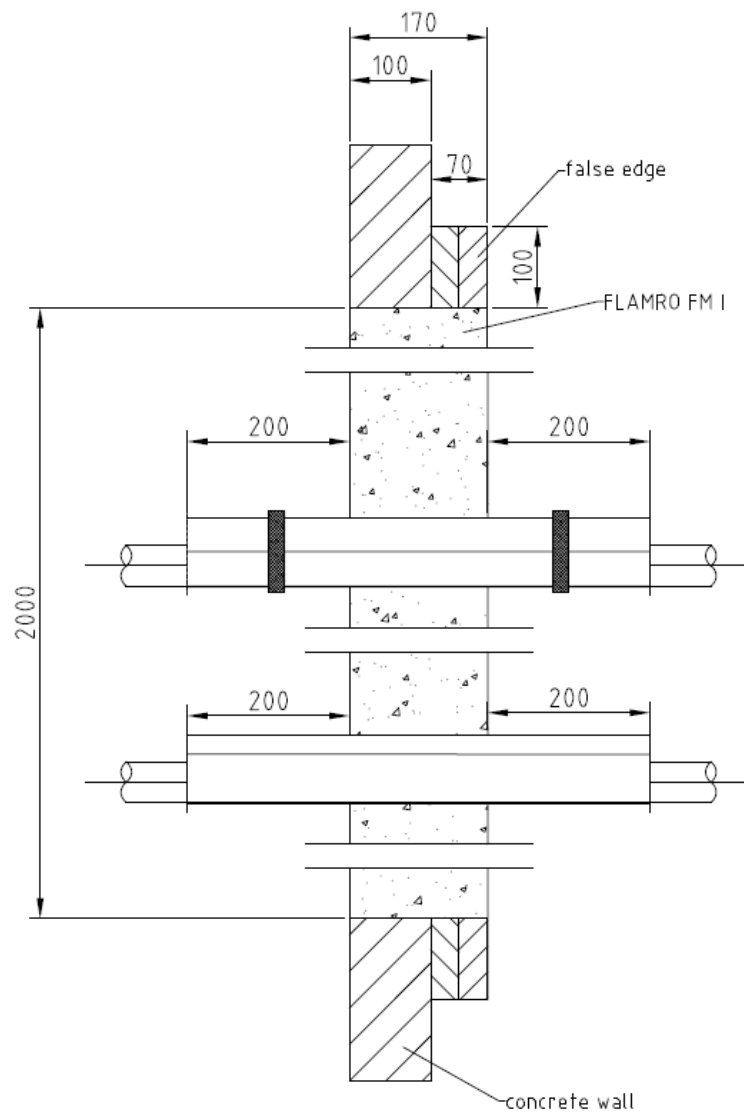
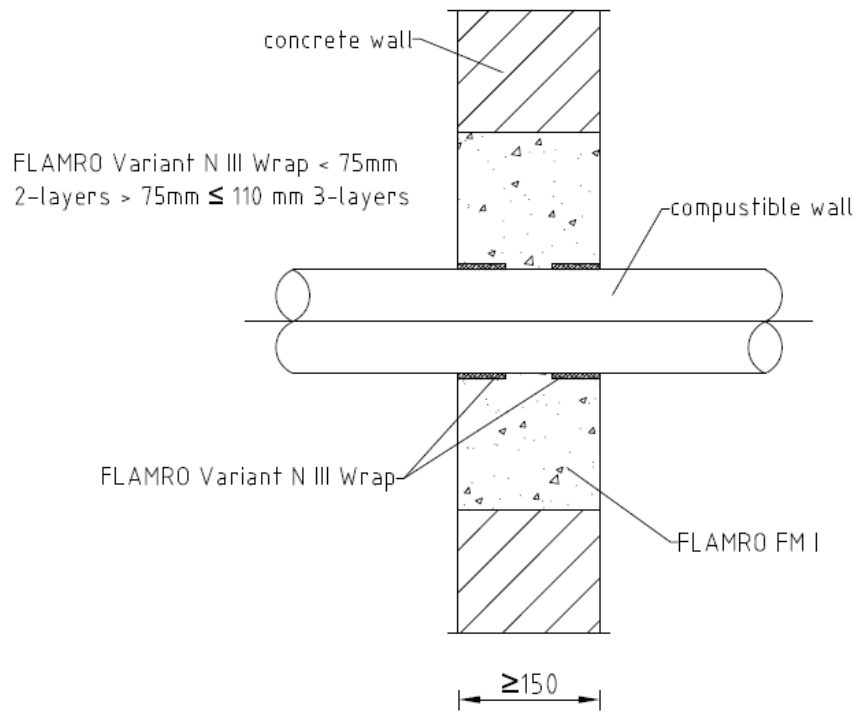

**Annex 4****Detailed description of the installation FLAMRO FM I Kombischott EN for the confirmation of fire resistance of penetration in 150 mm concrete slabs.**

The product performance of FLAMRO FM I Kombischott EN is the function of resisting fire in respect of the fire performance characteristics given in clause 5 of EN 13501-2.

The classification is declared under the following conditions:

The test was performed on a test specimen placed in an aerated concrete slab floor of 150 [mm] thickness including an opening gap. The opening is filled with the product FLAMRO FM I penetration sealing system. Copper and steel pipes protected by Armaflex Protect shells or Rockwool Klimarock mats.				
Pipes	Additional protection	E = Integrity	I = Insulation	pipe end configuration
1 copper pipe Ø 88,9 x 2 [mm]	Armaflex Protect shells 25 [mm] on full length and through the penetration	120	60	C/U
1 copper pipe Ø 22 x 1 [mm]	Armaflex Protect shells 20 [mm] on full length and through the penetration	120	90	C/U
1 copper pipe Ø 22 x 1 [mm]	Rockwool Klimarock mats 500 x 40 [mm] (length x thickness) on both sides and through the penetration + FLAMRO BaGe - KVB 250 x 1 [mm] (length x thickness) on fire side.	120	120	C/U
1 copper pipe Ø 89 x 2 [mm]	Rockwool Klimarock mats 500 x 40 [mm] (length*thickness) on both sides + FLAMRO BaGe - KVB 250 x 1 [mm] (length x thickness) on fire side.	120	120	C/U
1 copper pipe Ø 22 x 1 [mm]	Rockwool Klimarock mats 500 x 40 [mm] (length x thickness) on both sides + FLAMRO BaGe - KVB 250 x 1 [mm] (length x thickness) on fire side.	120	120	C/U
1 steel pipe Ø 42,4 x 2 [mm]	Rockwool Klimarock mats 500 x 40 [mm] (length x thickness) on both sides + FLAMRO BaGe - KVB 250 x 1 [mm] (length x thickness) on fire side.	120	120	C/U
1 steel pipe Ø 168,3 x 3,6 [mm]	Rockwool Klimarock mats 500 x 40 [mm] (length x thickness) on both sides and through the penetration + FLAMRO BaGe - KVB x 1 [mm] (length x thickness) on fire side.	120	120	C/U

The classification is declared under the following conditions:

The test was performed on a test specimen placed in an aerated concrete slab floor of 150 [mm] thickness including an opening gap. The opening is filled with the product FLAMRO FM I penetration sealing system. Plastic pipes protected by FLAMRO VARIANT N II A collars. Plastic pipes protected by FLAMRO VARIANT N III wrap.				
Pipes	Additional protection	E = Integrity	I = Insulation	pipe end configuration
1 PP pipe Ø 110 x 2,7 [mm]	FLAMRO VARIANT N II A collar on fire side	120	120	U/U
1 PP pipe Ø 50 x 1,8 [mm]	FLAMRO VARIANT N II A collar on fire side	120	120	U/U
1 PP pipe Ø 110 x 10 [mm]	FLAMRO VARIANT N II A collar on fire side	120	120	U/U
1 PP pipe Ø 50 x 4,6 [mm]	FLAMRO VARIANT N II A collar on fire side	120	120	U/U
1 PP pipe Ø 110 x 2,7 [mm]	3 layers FLAMRO VARIANT N III wrap through the penetration and flushed to the side	90	90	U/C
1 PP pipe Ø 110 x 10 [mm]		90	90	U/C
1 PP pipe Ø 75 x 1,9 [mm]	2 layers FLAMRO VARIANT N III wrap through the penetration and flushed to the side	120	120	U/C
1 PP pipe Ø 75 x 6,9 [mm]		120	120	U/C

The test was performed on a test specimen placed in an aerated concrete slab floor of 150 [mm] thickness including an opening gap. The opening is filled with the product FLAMRO FM I penetration sealing system. Plastic pipes protected by FLAMRO VARIANT N II A collars.				
Pipes	Additional protection	E = Integrity	I = Insulation	pipe end configuration
1 PVC-U pipe Ø 50 x 5,6 [mm]	FLAMRO VARIANT N II A collar on fire side	120	120	U/U
1 PVC-U pipe Ø 110 x 12,3 [mm]	FLAMRO VARIANT N II A collar on fire side	120	120	U/U
1 PVC-U pipe Ø 50 x 1,8 [mm]	FLAMRO VARIANT N II A collar on fire side	120	120	U/U
1 PVC-U pipe Ø 110 x 1,8 [mm]	FLAMRO VARIANT N II A collar on fire side	120	120	U/U

The test was performed on a test specimen placed in an aerated concrete slab floor of 150 [mm] thickness including an opening gap. The opening is filled with the product FLAMRO FM I penetration sealing system. Plastic pipes protected by FLAMRO VARIANT N II A collars.				
Pipes	Additional protection	E = Integrity	I = Insulation	pipe end configuration
1 PEHD pipe Ø 110 x 10 [mm]	FLAMRO VARIANT N II A collar on fire side	120	120	U/U
1 PEHD pipe Ø 50 x 4,6 [mm]	FLAMRO VARIANT N II A collar on fire side	120	120	U/U
1 PEHD pipe Ø 50 x 1,8 [mm]	FLAMRO VARIANT N II A collar on fire side	120	120	U/U
1 PEHD pipe Ø 110 x 2,7 [mm]	FLAMRO VARIANT N II A collar on fire side	120	120	U/U

The test was performed on a test specimen placed in an aerated concrete slab floor of 150 [mm] thickness including an opening gap. The opening is filled with the product FLAMRO FM I – penetration sealing system. Plastic pipes protected by FLAMRO VARIANT N III wrap.

Pipes	Additional protection	E = Integrity	I = Insulation	pipe end configuration
1 PE pipe Ø 110 x 2,7 [mm]	3 layers FLAMRO VARIANT N III wrap through the penetration and flushed to the side	120	120	U/C
1 PE pipe Ø 110 x 10 [mm]		120	120	U/C
1 PE pipe Ø 110 x 2,7 [mm]		120	120	U/C
1 PE pipe Ø 110 x 10 [mm]		120	120	U/C
1 PE pipe Ø 75 x 2 [mm]	2 layers FLAMRO VARIANT N III wrap through the penetration and flushed to the side	120	120	U/C
1 PE pipe Ø 75 x 6,9 [mm]		120	120	U/C

The test was performed on a test specimen placed in an aerated concrete slab floor of 150 [mm] thickness including an opening gap. The opening is filled with the product FLAMRO FM I – penetration sealing system. Plastic pipes protected by FLAMRO VARIANT N III wrap.

Pipes	Additional protection	E = Integrity	I = Insulation	pipe end configuration
1 PVC pipe Ø 110 x 1,8 [mm]	3 layers FLAMRO VARIANT N III wrap through the penetration and flushed to the side	120	120	U/C
1 PVC pipe Ø 110 x 12,3 [mm]		120	120	U/C
1 PVC pipe Ø 75 x 1,8 [mm]	2 layers FLAMRO VARIANT N III wrap through the penetration and flushed to the side	90	90	U/C
1 PVC pipe Ø 75 x 8,4 [mm]		120	120	U/C

The classification is declared under the following conditions:

The test was performed on a test specimen placed in an aerated concrete slab floor of 150 [mm] thickness including an opening gap. The opening is filled with the product FLAMRO FM I – penetration sealing system. For the standard cable module.					
Service/Cable group	Services	Additional protection	E = Integrity	I = Insulation	pipe end configuration
CABLE GROUP 1	10 A1 cables	FLAMRO BaGe - KVB 200 x 1 [mm](length x thickness) on both sides wrapped around the cable trays/ladders and cables or BC Brandschutz coating 200 x 1 [mm](length x thickness) on both sides on the cable trays/ladders and cables	120	120	-
	10 A2 cables		120	120	-
	10 A3 cables		120	120	-
	2 B cables		120	120	-
CABLE GROUP 2	1 C1 cable		120	120	-
	1 C2 cable		120	120	-
	1 C3 cable		120	120	-
	2 E cables		120	120	-
CABLE GROUP 3	1 D1 cable		120	120	-
	1 D2 cable		120	120	-
	1 D3 cable		120	120	-
CABLE GROUP 4	20 F cables		120	120	-
CABLE GROUP 5	1 G1 cable		120	120	-
	1 G2 cable		120	120	-
Service Group 6	3 steel tubes H: Ø16 [mm]	120	120	U/U	
	4 steel tubes I: Ø16 [mm]	120	120	U/U	

The classification is declared under the following conditions:

The test was performed on a test specimen placed in an aerated concrete slab floor of 150 [mm] thickness including an opening gap. The opening is filled with the product FLAMRO FM I – penetration sealing system. For the standard mixed module.					
Service/Cable group	Services	Additional protection	E = Integrity	I = Insulation	pipe end configuration
CABLE GROUP 1	10 A2 cables	FLAMRO BaGe - KVB 200 x 1 [mm] (length x thickness) on both sides wrapped around the cable trays/ladders and cables or BC Brandschutz coating 200 x 1 [mm](length x thickness) on both sides on the cable trays/ladders and cables	120	120	-
	2 B cables		120	120	-
CABLE GROUP 2	1 C2 cable		120	120	-
	2 E cables		120	120	-
CABLE GROUP 3	1 D3 cable		120	120	-
CABLE GROUP 4	20 F cables		120	120	-
CABLE GROUP 5	1 G2 cable		120	120	-
Service Group 6	3 steel tubes H: Ø16 [mm]		120	120	C/C
	4 steel tubes I: Ø16 [mm]		120	120	C/C

The classification is declared under the following conditions:

The test was performed on a test specimen placed in an aerated concrete slab floor of 150 [mm] thickness including an opening gap. The opening is filled with the product FLAMRO FM I – penetration sealing system. For the polyolefine cable conduits (empty) in bundle protected by FLAMRO Variant N II KS collar.				
Service	Cable group	Additional protection	E = Integrity	I = Insulation
3 conduits Ø 16 [mm]	None	FFKuS-EM-F Highspeed conduits end configuration C/C Coating BC Brandschutz in both sides of the cable conduits to close the conduits	120	120
3 conduits Ø 20 [mm]			120	120
3 conduits Ø 25 [mm]			120	120
2 conduits Ø 32 [mm]			120	120
1 conduits Ø 40 [mm]			120	120

The classification is declared under the following conditions:

The test was performed on a test specimen placed in an aerated concrete slab floor of 150 [mm] thickness including an opening gap. The opening is filled with the product FLAMRO FM I – penetration sealing system. For the polyolefine cable conduits (with cables) in bundle protected by FLAMRO VARIANT N II A collar.				
Service	Cable group	Additional protection	E = Integrity	I = Insulation
3 conduits Ø 16 [mm]	Conduits full with A1, A2, A2, B, E and F cables	FFKuS-EM-F Highspeed conduits end configuration C/C Coating BC Brandschutz in both sides of the cable conduits to close the conduits	120	120
3 conduits Ø 20 [mm]			120	120
3 conduits Ø 25 [mm]			120	120
2 conduits Ø 32 [mm]			120	120
1 conduits Ø 40 [mm]			120	120

The classification is declared under the following conditions:

The test was performed on a test specimen placed in an aerated concrete slab floor of 150 [mm] thickness including an opening gap. The opening is filled with the product FLAMRO FM I – penetration sealing system. For waveguides on a cable ladder.			
Service	Additional protection	E = Integrity	I = Insulation
3/8" HELIFLEX Air Dielectric Coaxial Cable	Rockwool Klimarock mats 300 x 40 [mm] (length x thickness) on both sides	120	120
1 - 1/8" HELIFLEX Air Dielectric Coaxial Cable		120	120
1 - 5/8" HELIFLEX Air Dielectric Coaxial Cable		120	120
FLEXWELL Standard Elliptical Waveguide E380		120	120
FLEXWELL Standard Elliptical Waveguide E38		120	120

The direct field of application is derived from the standard EN 1366-3:2009, and the classification is declared under the following conditions:

<p>Field of application (Chapter 7 of the classification report)</p>	<ul style="list-style-type: none"> <li>• Orientation, the test results and classification are applicable only for the orientation in which the penetration was tested, therefore in horizontal position for floors only.</li> <li>• Floor construction, the test results obtained with rigid standard supporting constructions may be applied to concrete or masonry separating elements of a thickness and density equal to or greater than that of the supporting construction used in the test. This rule does not apply to pipe closure devices positioned within the supporting construction in case of higher thickness of the supporting construction unless the length of the seal is increased by an equal amount and the distance from the surface of the supporting construction remains the same on both sides.</li> <li>• Services, the direct application of the rules apply to the external dimensions of the services.</li> <li>• Electric services, the cables are according to table A.1 of the EN 1366-3:20098 standards for the module 1 and according to F.2.3.1 option 1 for the second module.</li> <li>• Cable type, the tested cable groups 1 – 3 cover all cable types to the rules in 7.3.1.2 except tied bundles waveguides and non-sheathed cables (wires). Optical fibers cables are covered.             <ul style="list-style-type: none"> <li>▪ Test results achieved using cable group 5 according to Table. A.1 of EN 1366-3:2009 are valid for all non-sheathed cables (wires) subject to the rules in 7.3.1.2</li> <li>▪ Test results achieved using a tied bundle made from F-cables are valid for all tied bundles of cables subject to the rules in 7.3.1.2</li> </ul> </li> <li>• Cable size, the tested configuration with cable groups 1-3 cover cables to a maximum diameter of 80 mm             <ul style="list-style-type: none"> <li>▪ Test results of tied bundle made from F-cables are valid for tied bundles with a diameter of less than or equal to the bundle test of 100 mm made from cables with a diameter equal to or less than 21 mm</li> <li>▪ Test results for G1 are valid for all non-sheathed cables with a diameter of less than or equal to the bundle test of 17 mm. Test results for G2 are valid for all non-sheathed cables with a diameter of less than or equal to the bundle test of 24 mm</li> </ul> </li> <li>• Cable support, the results obtained from tests where the supports pass through the seal are applicable to those situations where the support does not. The reverse of this situation does not apply.             <ul style="list-style-type: none"> <li>▪ The test results obtained using standard configuration for cable penetration systems are not valid for lidded cable trays/trunkings where the lid passes through the penetration seal.</li> </ul> </li> </ul>
--	---

	<ul style="list-style-type: none"> <li>• Service group 6 according to Table A.2 the results achieved using service type H (conduits or tube) according to Table A.2 are valid for all steel conduits and steel tubes up to a diameter of 16 mm. The results achieved using type I according to Table A.2 are valid for all steel conduits and steel tubes up to the diameter of 16 mm.             <ul style="list-style-type: none"> <li>▪ Cable outlets out of the conduits/tubes must be sealed with BC-Brandschutz coating.</li> </ul> </li> <li>• Metal pipes, all pipe diameters referred to in this documents are external diameters because this controls the space to be filled by the sealing medium.</li> </ul>
Maximum size of the void	1200 x 1000 mm

**Annex 5****Detailed description of the installation FLAMRO FM I Kombischott EN for the confirmation of fire resistance of penetration in 100 [mm] block wall plus 2 x 35 [mm] Promatect plates.**

The product performance of FLAMRO FM I Kombischott EN is the function of resisting fire in respect of the fire performance characteristics given in clause 5 of EN 13501-2.

The classification is declared under the following conditions:

The test was performed on a test specimen placed in an aerated concrete block wall 100 [mm] thick plus 2 x 35 [mm] Promatect plates including opening gap. The opening is filled with the product FLAMRO FM I – penetration sealing system. Copper and steel pipes protected by Armaflex Protect shells or Rockwool Klimarock mats.				
Pipes	Additional protection	E = Integrity	I = Insulation	pipe end configuration
1 copper pipe Ø 88,9 x 2 [mm]	Armaflex Protect shells 25 [mm] on full length and through the penetration	120	90	C/U
1 copper pipe Ø 22 x 1 [mm]	Armaflex Protect shells 20 [mm] on full length and through the penetration	120	120	C/U
1 copper pipe Ø 22 x 1 [mm]	Rockwool Klimarock mats 500 x 40 [mm] (length x thickness) on both sides and through the penetration + FLAMRO BaGe - KVB 250 x 1 [mm] (length x thickness) on both sides.	120	120	C/U
1 copper pipe Ø 89 x 2 [mm]	Rockwool Klimarock mats 500 x 40 [mm] (length*thickness) on both sides + FLAMRO BaGe - KVB 250 x 1 [mm] (length x thickness) on both sides.	120	120	C/U
1 copper pipe Ø 22 x 1 [mm]	Rockwool Klimarock mats 500 x 40 [mm] (length x thickness) on both sides + FLAMRO BaGe - KVB 250 x 1 [mm] (length x thickness) on both sides.	120	120	C/U
1 steel pipe Ø 42,4 x 2 [mm]	Rockwool Klimarock mats 500 x 40 [mm] (length x thickness) on both sides + FLAMRO BaGe - KVB 250 x 1 [mm] (length x thickness) on both sides.	120	120	C/U
1 steel pipe Ø 168,3 x 3,6 [mm]	Rockwool Klimarock mats 500 x 40 [mm] (length x thickness) on both sides and through the penetration + FLAMRO BaGe - KVB 250 x 1 [mm] (length x thickness) on both sides.	120	120	C/U

The classification is declared under the following conditions:

The test was performed on a test specimen placed in an aerated concrete block wall 100 [mm] thick plus 2 x 35 [mm] Promatect plates including opening gap. The opening is filled with the product FLAMRO FM I – penetration sealing system.				
Plastic pipes protected by FLAMRO Variant N II A collars.				
Plastic pipes protected by FLAMRO VARIANT N III WRAP Strips.				
Pipes	Additional protection	E = Integrity	I = Insulation	pipe end configuration
1 PP pipe Ø 110 x 2,7 [mm]	FLAMRO VARIANT N II A collar on both sides	120	120	U/U
1 PP pipe Ø 50 x 1,8 [mm]	FLAMRO VARIANT N II A collar on both sides	120	120	U/U
1 PP pipe Ø 110 x 10 [mm]	FLAMRO VARIANT N II A collar on both sides	120	120	U/U
1 PP pipe Ø 50 x 4,6 [mm]	FLAMRO VARIANT N II A collar on both sides	120	120	U/U
1 PP pipe Ø 110 x 2,7 [mm]	3 layers FLAMRO VARIANT N III WRAP strip through the penetration and flushed to the fire side + 3 layers FLAMRO VARIANT N III WRAP strip through the penetration and flushed to the non fire side.	120	120	U/C
1 PP pipe Ø 110 x 10 [mm]		120	120	U/C
1 PP pipe Ø 75 x 1,9 [mm]	2 layers FLAMRO VARIANT N III WRAP strip through the penetration and flushed to the fire side + 2 layers FLAMRO VARIANT N III WRAP strip through the penetration and flushed to the non fire side.	120	120	U/C
1 PP pipe Ø 75 x 6,9 [mm]		120	120	U/C

The test was performed on a test specimen placed in an aerated concrete block wall 100 [mm] thick plus 2 x 35 [mm] Promatect plates including opening gap. The opening is filled with the product FLAMRO FM I – penetration sealing system. Plastic pipes protected by FLAMRO Variant N II A collars.				
Pipes	Additional protection	E = Integrity	I = Insulation	pipe end configuration
1 PVC-U pipe Ø 50 x 5,6 [mm]	FLAMRO VARIANT N II A collar on both sides	120	120	U/U
1 PVC-U pipe Ø 110 x 12,3 [mm]	FLAMRO VARIANT N II A collar on both sides	120	120	U/U
1 PVC-U pipe Ø 50 x 1,8 [mm]	FLAMRO VARIANT N II A collar on both sides	120	120	U/U
1 PVC-U pipe Ø 110 x 1,8 [mm]	FLAMRO VARIANT N II A collar on both sides	120	120	U/U

The test was performed on a test specimen placed in an aerated concrete block wall 100 [mm] thick plus 2 x 35 [mm] Promatect plates including opening gap. The opening is filled with the product FLAMRO FM I – penetration sealing system. Plastic pipes protected by FLAMRO Variant N II A collars.				
Pipes	Additional protection	E = Integrity	I = Insulation	pipe end configuration
1 PEHD pipe Ø 110 x 10 [mm]	FLAMRO VARIANT N II A collar on both sides	120	120	U/U
1 PEHD pipe Ø 50 x 4,6 [mm]	FLAMRO VARIANT N II A collar on both sides	120	120	U/U
1 PEHD pipe Ø 50 x 1,8 [mm]	FLAMRO VARIANT N II A collar on both sides	120	120	U/U
1 PEHD pipe Ø 110 x 2,7 [mm]	FLAMRO VARIANT N II A collar on both sides	120	120	U/U

The test was performed on a test specimen placed in an aerated concrete block wall 100 [mm] thick plus 2 x 35 [mm] Promatect plates including opening gap. The opening is filled with the product FLAMRO FM I – penetration sealing system. Plastic pipes protected by FLAMRO VARIANT N III WRAP Strips.				
Pipes	Additional protection	E = Integrity	I = Insulation	pipe end configuration
1 PE pipe Ø 110 x 2,7 [mm]	3 layers FLAMRO VARIANT N III WRAP strip through the penetration and flushed to the fire side + 3 layers FLAMRO VARIANT N III WRAP strip through the penetration and flushed to the non fire side.	120	120	U/C
1 PE pipe Ø 110 x 10 [mm]		120	120	U/C
1 PE pipe Ø 75 x 2 [mm]	2 layers FLAMRO VARIANT N III WRAP strip through the penetration and flushed to the fire side + 2 layers FLAMRO VARIANT N III WRAP strip through the penetration and flushed to the non fire side.	120	120	U/C
1 PE pipe Ø 75 x 6,9 [mm]		120	120	U/C

The test was performed on a test specimen placed in an aerated concrete block wall 100 [mm] thick plus 2 x 35 [mm] Promatect plates including opening gap. The opening is filled with the product FLAMRO FM I – penetration sealing system. Plastic pipes protected by FLAMRO VARIANT N III WRAP Strips.				
Pipes	Additional protection	E = Integrity	I = Insulation	pipe end configuration
1 PVC pipe Ø 110 x 1,8 [mm]	3 layers FLAMRO VARIANT N III WRAP strip through the penetration and flushed to the fire side + 3 layers FLAMRO VARIANT N III WRAP strip through the penetration and flushed to the non fire side.	120	120	U/C
1 PVC pipe Ø 110 x 12,3 [mm]		120	120	U/C
1 PVC pipe Ø 75 x 1,8 [mm]	2 layers FLAMRO VARIANT N III WRAP strip through the penetration and flushed to the fire side + 2 layers FLAMRO VARIANT N III WRAP strip through the penetration and flushed to the non fire side.	120	120	U/C
1 PVC pipe Ø 75 x 8,4 [mm]		120	120	U/C

The classification is declared under the following conditions:

The test was performed on a test specimen placed in an aerated concrete block wall 100 [mm] thick plus 2 x 35 [mm] Promatect plates including opening gap. The opening is filled with the product FLAMRO FM I – penetration sealing system. For the standard cable module.					
Service/Cable group	Services	Additional protection	E = Integrity	I = Insulation	pipe end configuration
CABLE GROUP 1	10 A1 cables	FLAMRO BaGe - KVB 200 x 1 [mm] (length x thickness) on both sides wrapped around the cable trays/ladders and cables or BC Brandschutz coating 200 x 1 [mm] (length x thickness) on both sides on the cable trays/ladders and cables	120	120	-
	10 A2 cables		120	120	-
	10 A3 cables		120	120	-
	2 B cables		120	120	-
CABLE GROUP 2	1 C1 cable		120	120	-
	1 C2 cable		120	120	-
	1 C3 cable		120	120	-
	2 E cables		120	120	-
CABLE GROUP 3	1 D1 cable		120	120	-
	1 D2 cable		120	120	-
	1 D3 cable		120	120	-
CABLE GROUP 4	20 F cables		120	120	-
CABLE GROUP 5	1 G1 cable		120	120	-
	1 G2 cable		120	120	-
Service Group 6	3 steel tubes H: Ø16 [mm]	120	120	U/U	
	4 steel tubes I: Ø16 [mm]	120	120	U/U	

The classification is declared under the following conditions:

The test was performed on a test specimen placed in an aerated concrete block wall 100 [mm] thick plus 2 x 35 [mm] Promatect plates including opening gap. The opening is filled with the product FLAMRO FM I – penetration sealing system. For the standard mixed module.					
Service/Cable group	Services	Additional protection	E = Integrity	I = Insulation	pipe end configuration
CABLE GROUP 1	10 A2 cables	FLAMRO BaGe - KVB 200 x 1 [mm] (length x thickness) on both sides wrapped around the cable trays/ladders and cables or BC Brandschutz coating 200 x 1 [mm] (length x thickness) on both sides on the cable trays/ladders and cables	120	120	-
	2 B cables		120	120	-
CABLE GROUP 2	1 C2 cable		120	120	-
	2 E cables		120	120	-
CABLE GROUP 3	1 D3 cable		120	120	-
CABLE GROUP 4	20 F cables		120	120	-
CABLE GROUP 5	1 G2 cable		120	120	-
Service Group 6	3 steel tubes H: Ø16 [mm]		120	120	U/U
	4 steel tubes I: Ø16 [mm]		120	120	U/U

The classification is declared under the following conditions:

The test was performed on a test specimen placed in an aerated concrete block wall 100 [mm] thick plus 2 x 35 [mm] Promatect plates including opening gap. The opening is filled with the product FLAMRO FM I – penetration sealing system. For the polyolefine cable conduits (empty) in bundle protected by FLAMRO Variant N II KS collar.				
Service	Cable group	Additional protection	E = Integrity	I = Insulation
3 conduits Ø 16 [mm]	None	FFKuS-EM-F Highspeed conduits end configuration C/C Coating BC Brandschutz in both sides of the cable conduits to close the conduits	120	120
3 conduits Ø 20 [mm]			120	120
3 conduits Ø 25 [mm]			120	120
2 conduits Ø 32 [mm]			120	120
1 conduits Ø 40 [mm]			120	120

The classification is declared under the following conditions:

The test was performed on a test specimen placed in an aerated concrete block wall 100 [mm] thick plus 2 x 35 [mm] Promatect plates including opening gap. The opening is filled with the product FLAMRO FM I – penetration sealing system. For the polyolefine cable conduits (with cables) in bundle protected by FLAMRO VARIANT N II A collar.				
Service	Cable group	Additional protection	E = Integrity	I = Insulation
3 conduits Ø 16 [mm]	Conduits full with A1, A2, A2, B, E and F cables	FFKuS-EM-F Highspeed conduits end configuration C/C Coating BC Brandschutz in both sides of the cable conduits to close the conduits	120	120
3 conduits Ø 20 [mm]			120	120
3 conduits Ø 25 [mm]			120	120
2 conduits Ø 32 [mm]			120	120
1 conduits Ø 40 [mm]			120	120

The classification is declared under the following conditions:

The test was performed on a test specimen placed in an aerated concrete block wall 100 [mm] thick plus 2 x 35 [mm] Promatect plates including opening gap. The opening is filled with the product FLAMRO FM I – penetration sealing system. For waveguides on a cable ladder.				
Service	Additional protection	E = Integrity	I = Insulation	
3/8" HELIFLEX Air Dielectric Coaxial Cable	Rockwool Klimarock mats 400 x 40 [mm] (length x thickness) on both sides	120	120	
1 - 1/8" HELIFLEX Air Dielectric Coaxial Cable		120	120	
1 - 5/8" HELIFLEX Air Dielectric Coaxial Cable		120	120	
FLEXWELL Standard Elliptical Waveguide E380		120	120	
FLEXWELL Standard Elliptical Waveguide E38		120	120	

The direct field of application is derived from the standard EN 1366-3:2009, and the classification is declared under the following conditions:

<p>Field of application (Chapter 7 of the classification report)</p>	<ul style="list-style-type: none"> <li>• Orientation, the test results and classification are applicable only for the orientation in which the penetration was tested, therefore in horizontal position for floors only.</li> <li>• The test results obtained with rigid standard supporting constructions may be applied to concrete or masonry separating elements of a thickness and density equal to or greater than that of the supporting construction used in the test. The 100 mm aerated concrete blocks may be increased provided that the 2 x 35 mm Promatct plates stay equal. This rule does not apply to pipe closure devices positioned within the supporting construction in case of higher thickness of the supporting construction unless the length of the seal is increased by an equal amount and the distance from the surface of the supporting construction remains the same on both sides.</li> <li>• Services, the direct application of the rules apply to the external dimensions of the services.</li> <li>• Electric services, the cables are according to table A.1 of the EN 1366-3:2009 standards for the module 1 and according to F.2.3.1 option 1 for the second module.</li> <li>• Cable type, the tested cable groups 1 – 3 cover all cable types to the rules in 7.3.1.2 except tied bundles waveguides and non-sheathed cables (wires). Optical fibers cables are covered.             <ul style="list-style-type: none"> <li>▪ Test results achieved using cable group 5 according to Table. A.1 of EN 1366-3:2009 are valid for all non-sheathed cables (wires) subject to the rules in 7.3.1.2</li> <li>▪ Test results achieved using a tied bundle made from F-cables are valid for all tied bundles of cables subject to the rules in 7.3.1.2</li> </ul> </li> <li>• Test results for the configuration with cable groups 1-3 cover cables to a maximum diameter of 80 mm             <ul style="list-style-type: none"> <li>▪ Test results of tied bundle made from F-cables are valid for tied bundles with a diameter of less than or equal to the bundle test of 100 mm made from cables with a diameter equal to or less than 21 mm</li> <li>▪ Test results for G1 are valid for all non-sheathed cables with a diameter of less than or equal to the bundle test of 17 mm. Test results for G2 are valid for all non-sheathed cables with a diameter of less than or equal to the bundle test of 24 mm</li> </ul> </li> <li>• Cable support, the results obtained from tests where the supports pass through the seal are applicable to those situations where the support does not. The reverse of this situation does not apply.             <ul style="list-style-type: none"> <li>▪ The test results obtained using standard configuration for cable penetration systems are not valid for lidded cable trays/trunkings where the lid passes through the penetration seal.</li> </ul> </li> </ul>
--	--

	<ul style="list-style-type: none"> <li>• Service group 6 according to Table A.2 the results achieved using service type H (conduits or tube) according to Table A.2 are valid for all steel conduits and steel tubes up to a diameter of 16 mm. The results achieved using type I according to Table A.2 are valid for all steel conduits and steel tubes up to the diameter of 16 mm.             <ul style="list-style-type: none"> <li>▪ Cable outlets out of the conduits/tubes must be sealed with BC-Brandschutz coating.</li> </ul> </li> <li>• Metal pipes, all pipe diameters referred to in this documents are external diameters because this controls the space to be filled by the sealing medium.</li> </ul>
Maximum size of the void	1200 x 2000 mm